

INFORMATION AND DIMENSIONS ARE AN INDICATIVE GUIDE ONLY

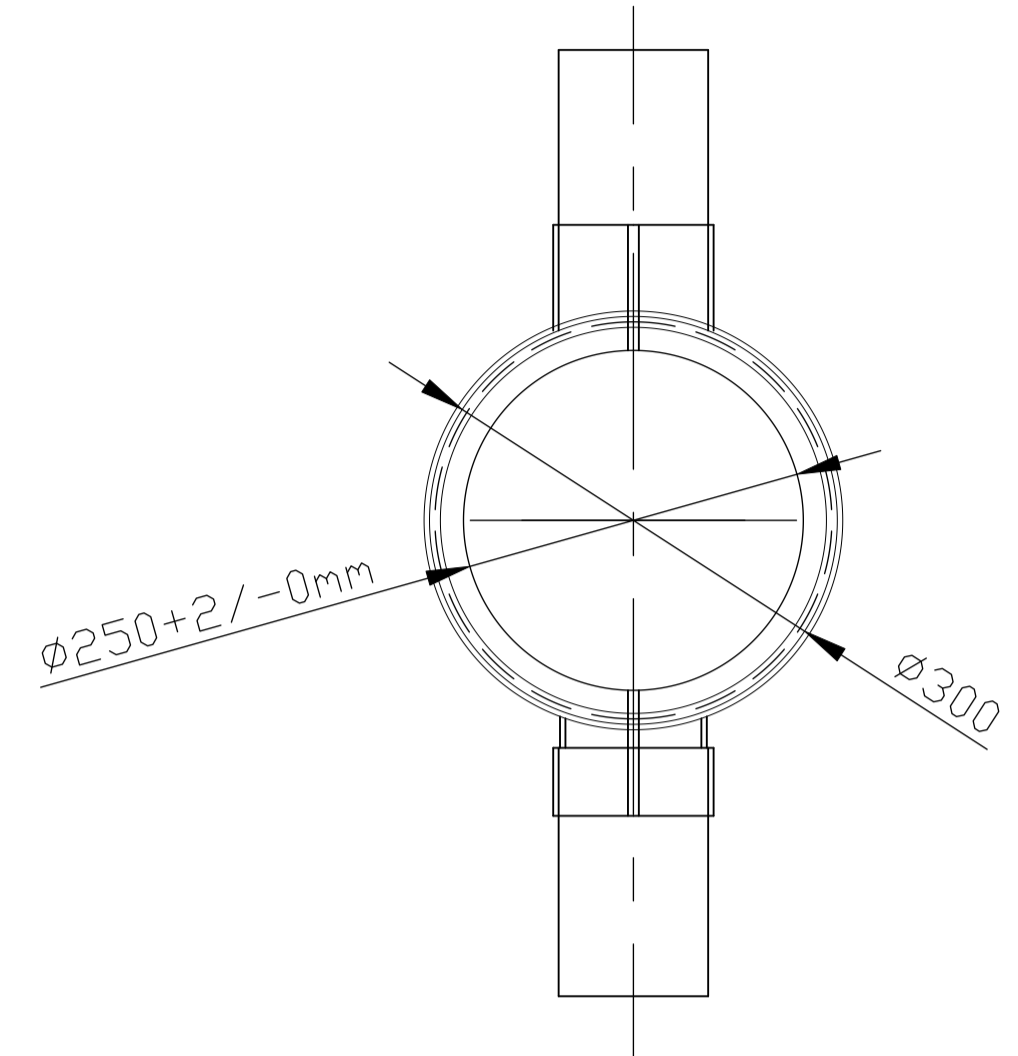

PLAN VIEW

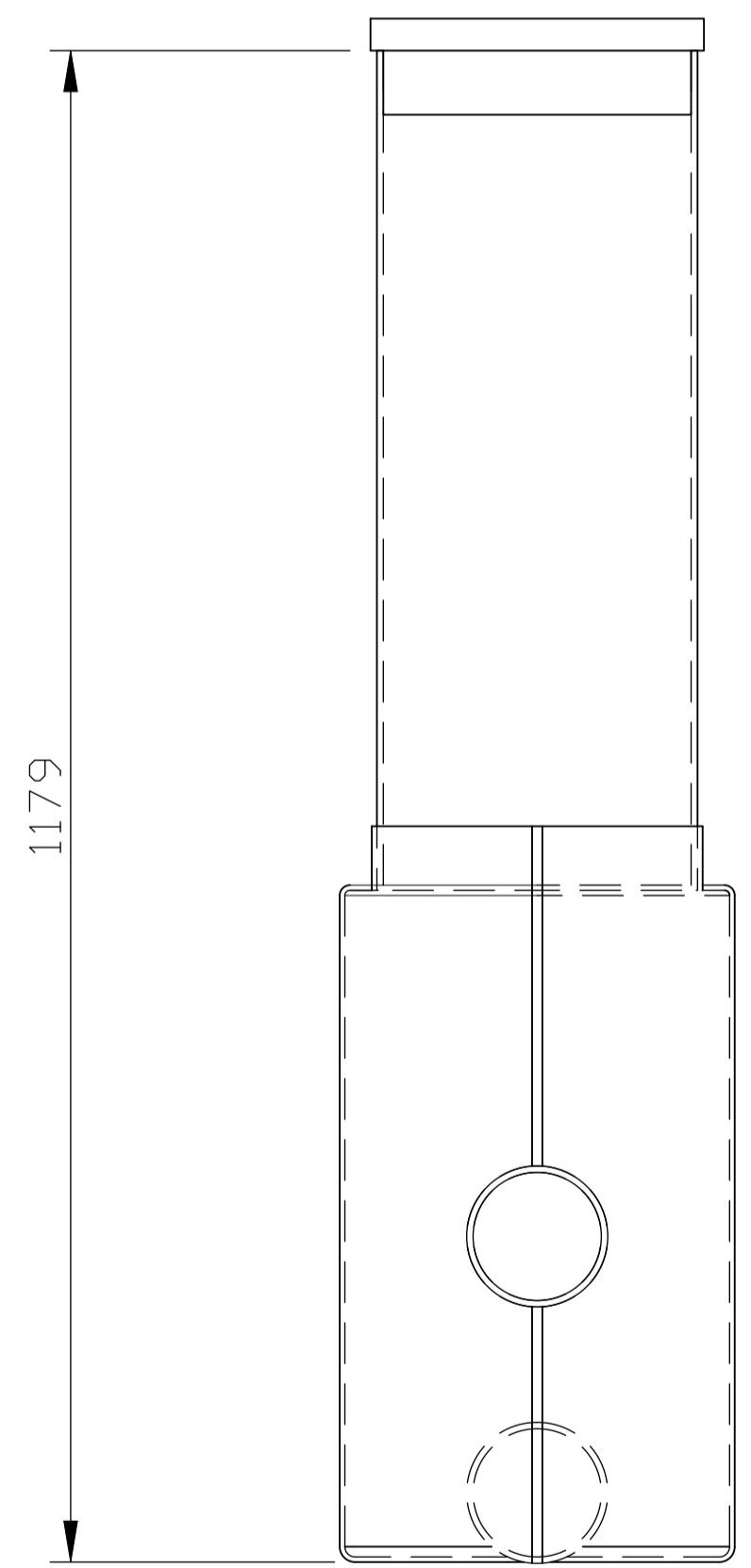

FRONT VIEW

INLET
110Ø
SOIL PIPE
TO BS4660

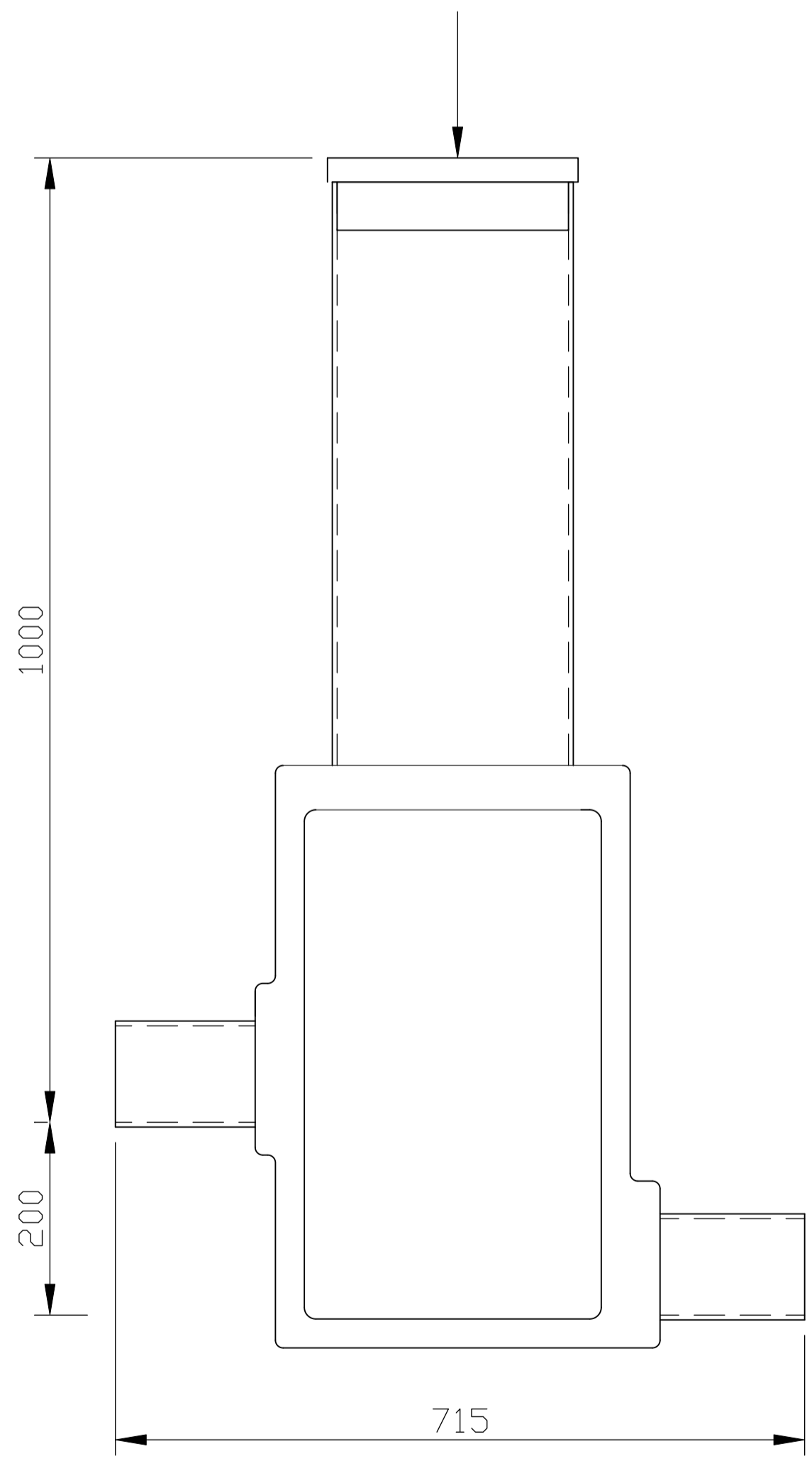

SIDE VIEW

OUTLET
110Ø
SOIL PIPE
TO BS4660

DRAWING APPROVAL	DRAWING NO.	VERSION
DATE	SAMPLE CHAMBER	A
APPROVED BY (PRINT)	NOTES	
SIGNED:	1. DIMENSIONS ARE SUBJECT TO DIMENSIONAL TOLERANCES. 2. ALL DIMENSIONS IN MILLIMETERS AND ALL LEVELS IN METRES UNLESS SHOWN OTHERWISE. 3. DRAWING IN THIRD ANGLE PROJECTION.	

REFERENCES:

LEGEND

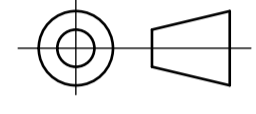

CURRENT VERSION INFORMATION

DATE	DRWN	CHKD	REVD	VER	REASON FOR ISSUE
16/08/2021	TC			A	FIRST ISSUE

THIS DRAWING IS ISSUED BY WPL (A WCS GROUP COMPANY) SUBJECT TO THE CONDITIONS THAT IT IS NOT COPIED EITHER IN WHOLE OR IN PART OR DISCLOSED TO THIRD PARTIES UNLESS PRIOR WRITTEN AUTHORIZATION IS GIVEN BY WPL (A WCS GROUP COMPANY). IF PRINTED, THE DRAWING WILL BE UNCONTROLLED. PREVIOUS VERSIONS OF THIS DRAWING SHOULD BE STAMPED SUPERSEDED OR DESTROYED. DO NOT SCALE THIS DRAWING - IF IN DOUBT ASK.

WEIGHTS + DIMENSIONS:

WEIGHTS 01:
EMPTY WEIGHT 5KG

LIFTING POINTS
MARKED AS AN ENCIRCLED L

ANY DESIGNS OR INNOVATIONS REPRESENTED IN THE DRAWING SPACE ARE THE SOLE OWNERSHIP OF WPL (A WCS GROUP COMPANY) AND AS SUCH COPYRIGHT AND DESIGN RIGHTS IMPLICITLY APPLY.



ORIGINATORS DRAWING NO.	VERSION
SAMPLE CHAMBER	A

PROJECT TITLE
SAMPLE CHAMBER

DRAWING TITLE
GENERAL ASSEMBLY

SITE	SITE No
SITE NAME	

SCALE	MASTER SIZE
N.T.S	A1

DRAWING NO.	VERSION
SAMPLE CHAMBER	A