

<b>DRAWING APPROVAL</b>		DRAWING NO.	VERSION
DATE	DMC8/9		A
APPROVED BY (PRINT)			
SIGNED:			

NOTES  
 1. DIMENSIONS ARE SUBJECT TO DIMENSIONAL TOLERANCES.  
 2. ALL DIMENSIONS IN MILLIMETERS AND ALL LEVELS IN METRES UNLESS SHOWN OTHERWISE.

REFERENCES:

CURRENT VERSION INFORMATION

DATE	DRWN	CHKD	REVD	VER	REASON FOR ISSUE
28/10/2022	TC			A	FIRST ISSUE

THIS DRAWING IS ISSUED BY WCS ENVIRONMENTAL ENGINEERING SUBJECT TO THE CONDITIONS THAT IT IS NOT COPIED EITHER IN WHOLE OR IN PART OR DISCLOSED TO THIRD PARTIES UNLESS PRIOR WRITTEN AUTHORISATION IS GIVEN BY WPL (A WCS GROUP COMPANY). IF PRINTED, THE DRAWING WILL BE UNCONTROLLED. PREVIOUS VERSIONS OF THIS DRAWING SHOULD BE STAMPED SUPERSEDED OR DESTROYED. DO NOT SCALE THIS DRAWING - IF IN DOUBT ASK

WEIGHTS & DIMENSIONS	
WEIGHTS 01:	
EMPTY WEIGHT	460kg
SHIPPING DIMS 01	
LENGTH	3300mm
WIDTH	3300mm
HEIGHT	3400mm

ANY DESIGNS OR INNOVATIONS REPRESENTED IN THE DRAWING SPACE ARE THE SOLE OWNERSHIP OF WCS ENVIRONMENTAL ENGINEERING AND AS SUCH COPYRIGHT AND DESIGN RIGHTS IMPLICITLY APPLY.



ORIGINATORS DRAWING NO.	VERSION
DMC8/9	A

PROJECT TITLE  
 WPL DIAMOND

DRAWING TITLE  
 DMC8/9  
 DMC8 POPULATION = 36-45  
 DMC9 POPULATION = 46-55

SITE	SITE No

SCALE	MASTER SIZE
N.T.S	A1

DRAWING NO.	VERSION
DMC8/9	A

FOR QUOTATION PURPOSES ONLY

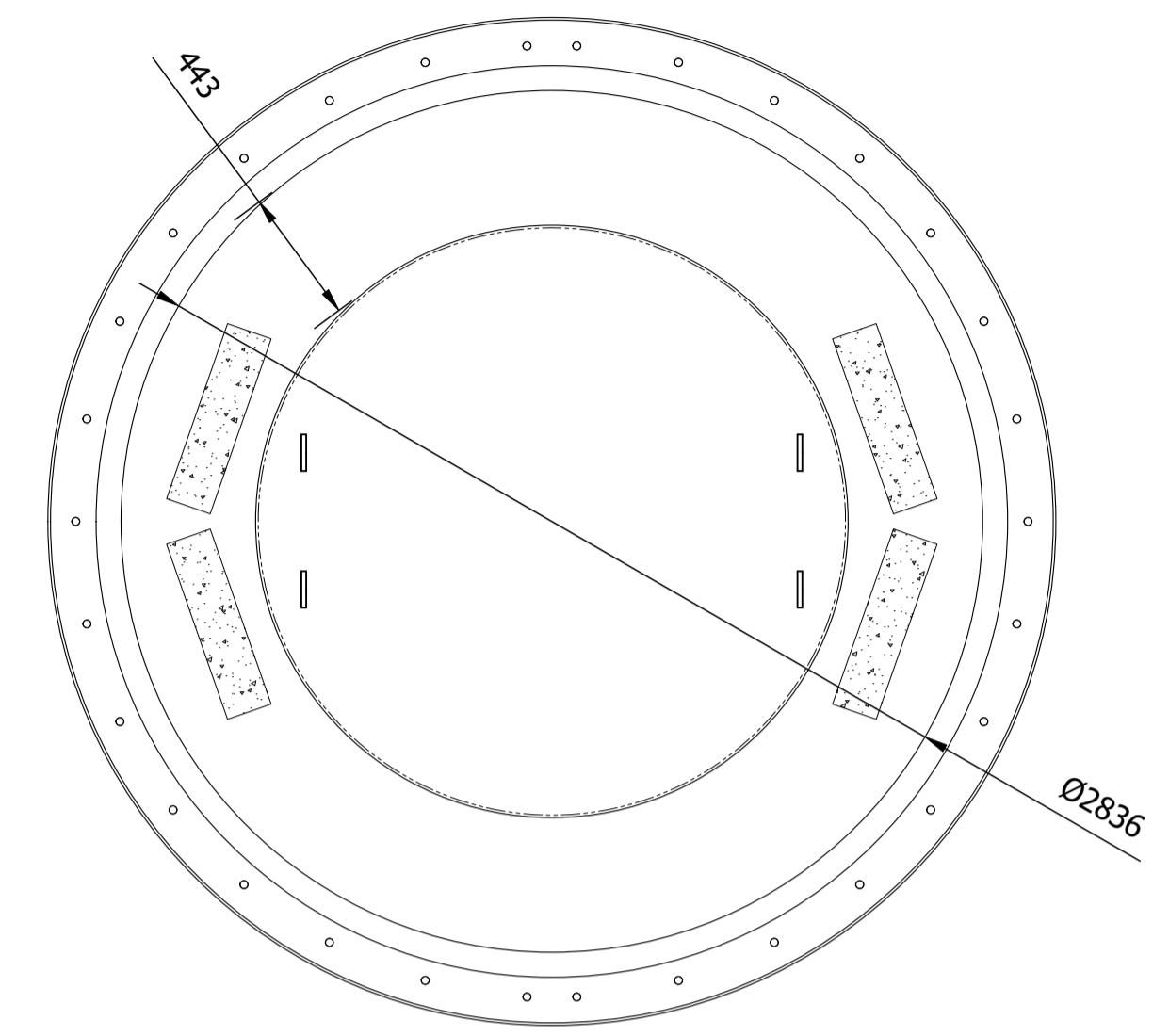

PLAN VIEW

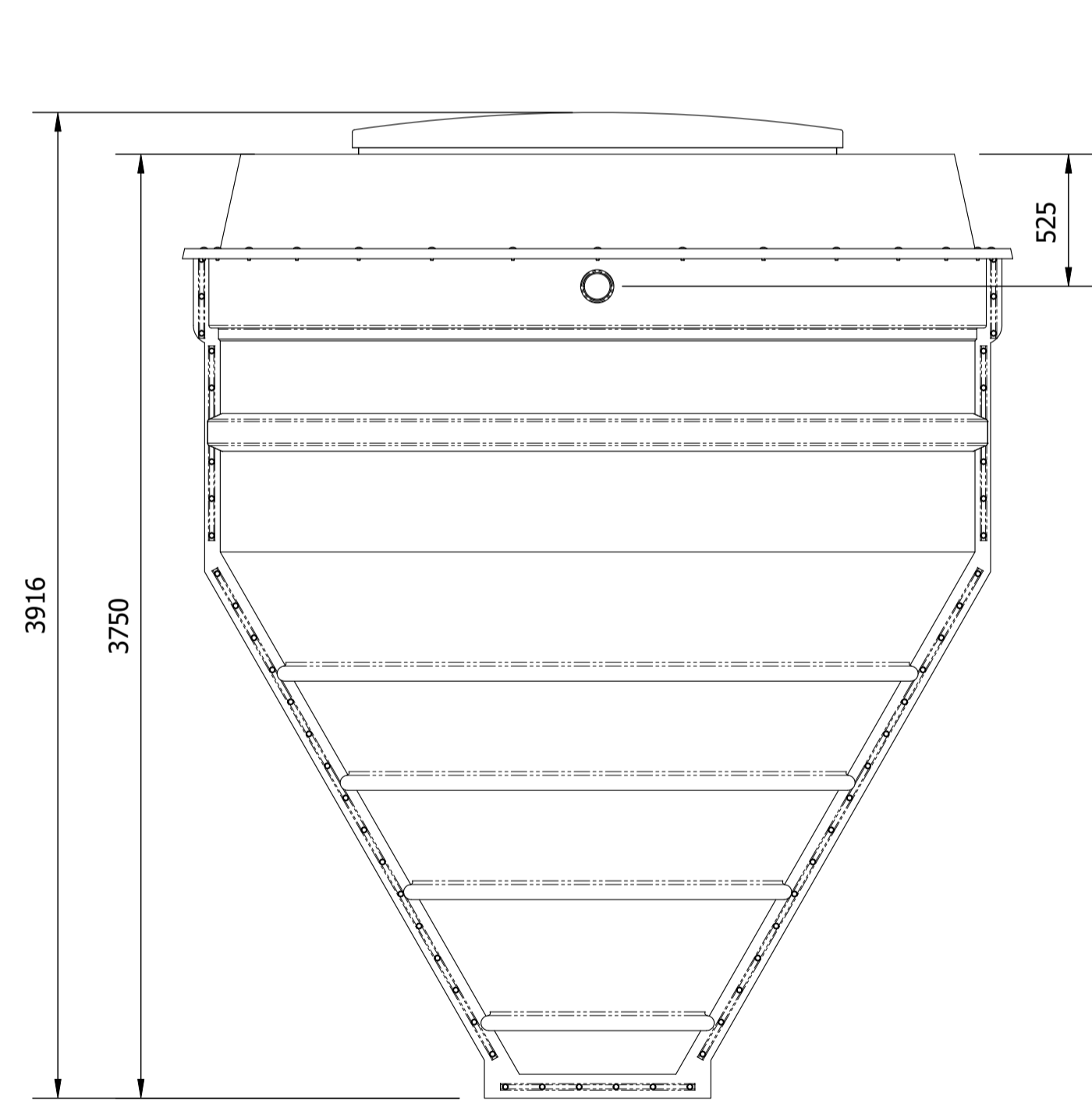

INLET VIEW

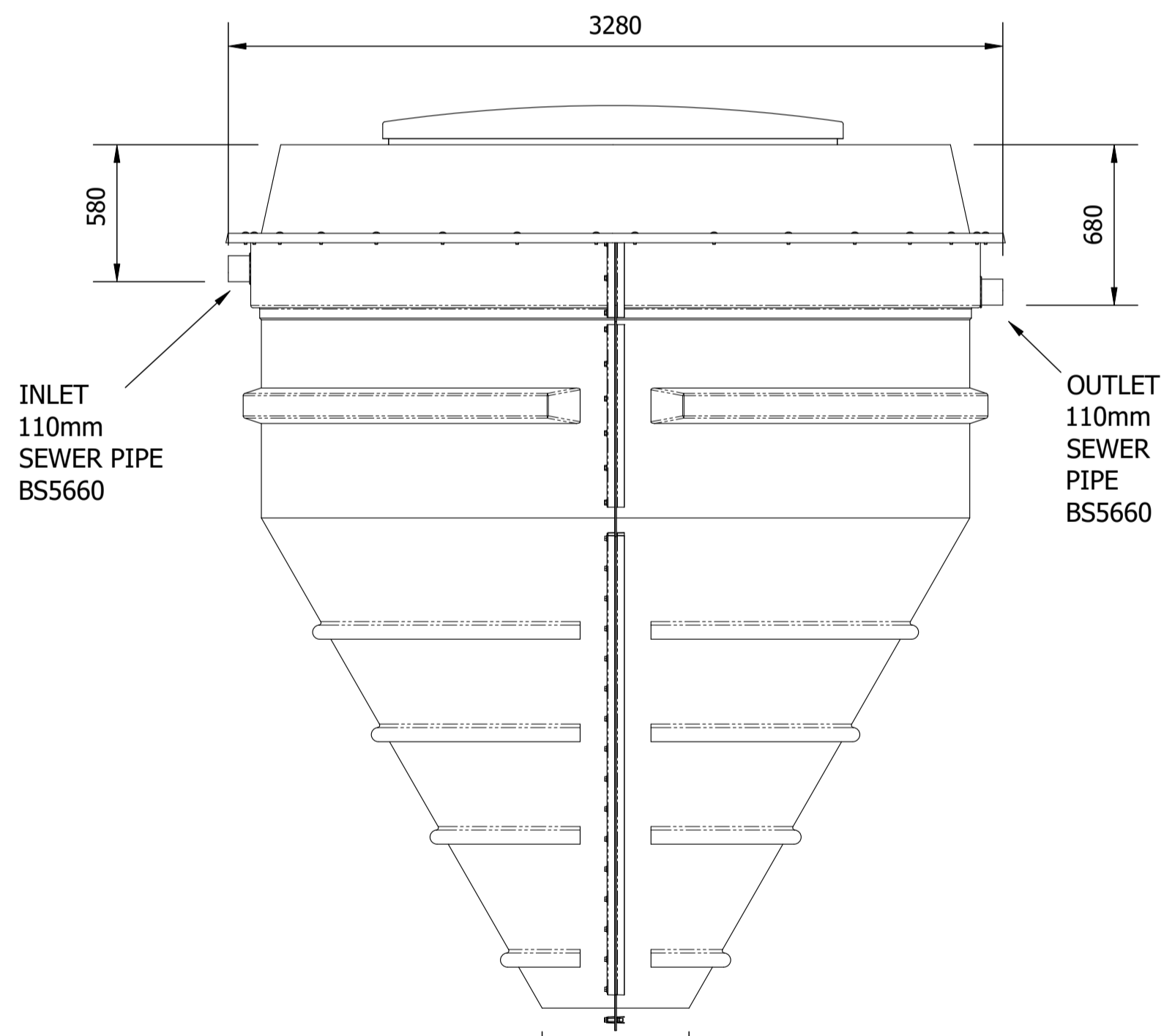

SIDE VIEW

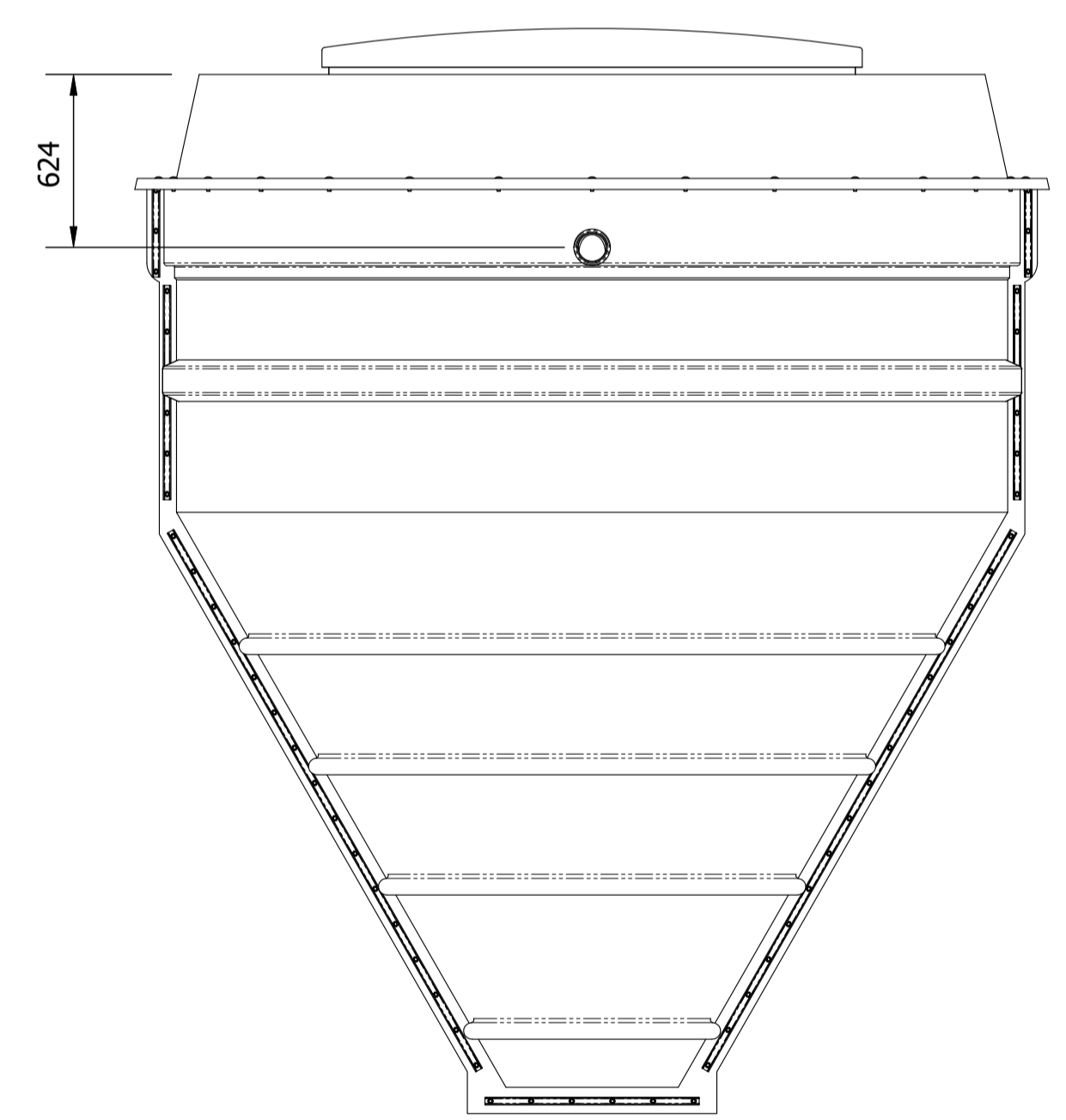

OUTLET VIEW